

INSTALLATION PROCEDURE

Copper Decorative Architectural Trim products by CCMi Corporation have been designed to be installed on a variety of exterior surfaces. Professional installation is recommended. With proper tools and instruction: exterior trim contractors, siding installers or carpenters can achieve professional installations. For best installation results follow these instructions.

IMPORTANT: READ ALL INSTRUCTIONS BEFORE BEGINNING INSTALLATION. When using power tools or other tools and equipment always read applicable warnings and follow the manufacturer's safety instructions. ALSCO recommends that you always wear appropriate dust mask, eye and hand protection to avoid injury when fabricating, and installing CCMi Products.

INSTALLATION OF CCMi COPPER FRIEZE TRIM FLUSH, J-CHANNEL & BRICK POCKET

Tools and Equipment: Normal siding applicator tools and a 12-inch slide compound miter saw with a non-ferrous metal or other suitable fine toothed blade are all that is required to install Frieze Trim. A handsaw is necessary for cutting the brick pocket foam mounting block.

Additional Materials Required: To mount the foam mounting block use Silicone-based or polyurethane-base adhesive, such as OSI HM-270 Silicone Sealer or OSI PL Premium. To seal joints use Silicone-based or acrylic urethane-based sealants, such as OSI HM-270 Silicone Sealer or OSI H2U. Hot-dipped galvanized 16-penny spikes or 3 inch hot-dipped galvanized roofing nails for the Flush or J-channel configurations, and hot-dipped galvanized or aluminum 8 inch gutter spikes for the brick pocket configuration.

IMPORTANT: DO NOT USE COMMON PETROLEUM-BASED CONSTRUCTION ADHESIVES, SUCH AS LIQUID NAILS BECAUSE SUCH PRODUCTS WILL DAMAGE AND ERODE THE FOAM, PREVENTING PROPER BONDING.

Additional Accessories: Prefabricated inside and outside corner pieces, universal end caps.

General Instructions: Frieze Trim uses a patent pending foam mounting block system that eliminates all nailing through the metal frieze. DO NOT nail the metal portion of the frieze. To install Frieze Trim, first determined which foam mounting block (Flush, J-channel or Brick pocket, each of which is discussed below) is necessary for proper installation. The recommended method for cutting Frieze Trim is to use a 12-inch slide compound miter saw with a non-ferrous metal or other suitable fine toothed blade. **ALWAYS CUT FRIEZE TRIM WITH THE FOAM MOUNTING BLOCK IN PLACE. WHEN CUTTING THE BRICK-POCKET CONFIGURATION, USE THE FLUSH MOUNT FOAM SUPPLIED AS A CUTTING AID.**

CCMi Copper Frieze Trim has a field-adjustable J-channel soffit receiver that is pre-set to accept standard 1/2 inch thick aluminum or vinyl soffits. It may be adjusted to accept soffits that are thinner or thicker by carefully closing or opening up the J-channel with your hands before installing.

Installation Order: Make a mark on the house wall at each end of the selected run that is level with the bottom of the fascia board and strike a chalk line. Following attachment instructions in the applicable section below, install the top of the foam mounting blocks even with the chalk line. If the run is going to go around corners, always install prefabricated corners before installing the straight pieces of mounting block. *NOTE: For best results, laps should be faced away from common lines of sight such as doors and driveways when possible.*

Prefabricated inside and outside corner pieces are available for Frieze Trim. However, Frieze Trim can be mitered to create an inside or outside corner, or bay miter by using the 12-inch slide compound miter saw. See special instruction below on miters and overlaps.

Prefabricated universal end caps are available to finish the ends of Frieze Trim. However, you may make end caps by scribing the profile pattern slightly larger (1/16 inch) on a piece of matching Copper Coil and cutting on the line with a metal shear or utility knife. *NOTE Making the end caps slight larger will allow for a caulking bead and produce a more "finished look".*



THIS PRODUCT INCLUDES EXPANDED POLYSTYRENE (EPS), OR FOAM MOUNTING BLOCK, AS A COMPONENT. MODIFIED EPS, LIKE MOST PLASTIC FOAMS, IS FLAMMABLE. DO NOT EXPOSE EPSTO OPEN FLAMES OR OTHER DIRECT OR INDIRECT HIGH TEMPERATURE: IGNITION SOURCES SUCH AS BURNING OPERATIONS, WELDING, BURNING CIGARETTES, SPACE HEATERS OR NAKED LIGHTS. WHEN BURNING, EPS WILL CONSUME OXYGEN, RELEASING GREAT HEAT AND SMOKE AND POTENTIALLY TOXIC GASES SUCH AS CARBON MONOXIDE AND CARBON DIOXIDE. DO NOT USE, INSTALL OR STORE EPS EXCEPT IN STRICT COMPLIANCE WITH BOCA, ICBO, SBCCI, IBC or NFPA 5000 CODES, AS WELL AS ANY FIRE-RELATED LAWS / ORDINANCES. FAILURE TO COMPLY WITH THESE CODES / LAWS MAY INCREASE THE RISK OF FIRE AND RESULT IN PERSONAL INJURY OR PROPERTY DAMAGE FROM SMOKE, FLAMES, OR WATER.

INSTALLATION OF CCMi COPPER FLUSH FRIEZE OVER BRICK, STONE OR STUCCO

Attaching the Flush Mount Foam Mounting Block

Apply 1/4 inch to 3/8 inch bead of adhesive to the foam mounting block as shown in fig.1.1. After striking the caulk line (see installation order on page 1), line up the top edge of the foam mounting block with the chalk line and press it firmly against the side of the house (Fig 1.2). While holding mounting block in place, nail the flush mount foam mounting block to the outside of the pre-framed brick pocket using hot-dipped galvanized 3-inch roofing nails or hot-dipped galvanized 16-penny spikes (Fig 1.3). The nails should be placed no more than 16-24 inches apart and must penetrate a minimum of 3/4 inch into solid wood or 1/2 inch into plywood or OSB. Generally, there should be no need for additional framing material as Flush Frieze covers the exposed brick pocket.

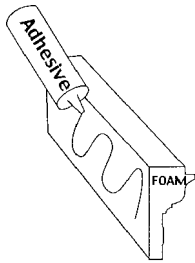

Fig. 1.1

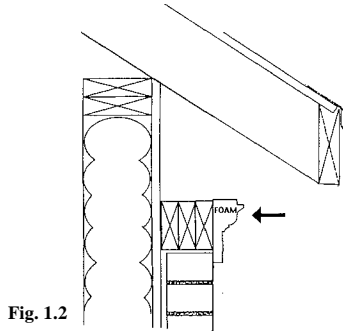

Fig. 1.2

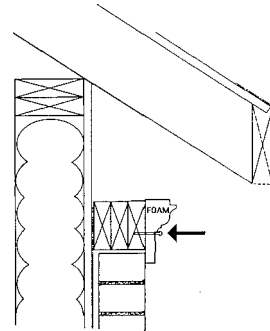

Fig. 1.3

CCMi details and drawings are illustrations of construction. They are guidelines, intended for use by the installer to assist with the installation. They should be modified where necessary to accommodate individual project conditions. Refer to local building codes for any special requirements.

Attaching the Frieze Trim

After the foam mounting blocks are attached, hook the bottom of the Frieze Trim to the foam mounting block (Fig 1.4) and rotate the Frieze Trim upwards and lock in place (Fig 1.5). Next, install soffit panels by inserting one end of the soffit panel all the way into the pre-formed J-channel on the top of the Frieze Trim (Fig 1.6) and nailing the other end of the soffit panel to the bottom of the fascia board using aluminum nails (Fig 1.7). Cover the fascia board.

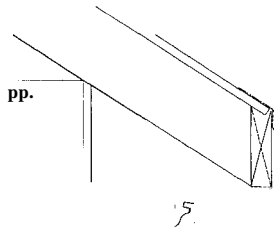

Fig. 1.4

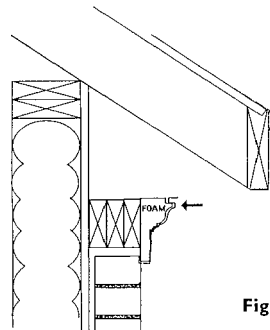

Fig. 1.5

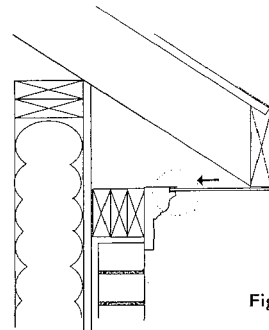

Fig. 1.6

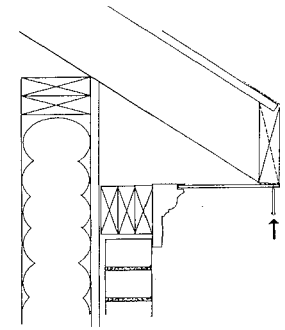

Fig. 1.7

The same procedures as above should be used to install Frieze Trim over stone or stucco.

INSTALLATION OF CCMi COPPER J-CHANNEL FRIEZE WITH ALL TYPES OF SIDING (VINYL, ALUMINUM, OR COMPOSITE)

J-Channel Frieze Trim has a cut-out that provides a built-in pocket that eliminates J-channel or finish trim at the top of the wall where it meets the frieze board.

Install the siding, per manufactured recommendations, up to the point where the J-Channel Frieze Trim cut-out pocket will cover the top edge or the top course of siding (Fig 2.0).

Attaching the foam mounting block

Apply 1/4 inch to 3/8 inch bead of adhesive to the foam mounting block as shown in Fig 2.1. After striking the chalk line (see Installation Order on page I) line up the top edge of the foam mounting block with the chalk line (see installation order on page I) and press it firmly against the side of the house (Fig 2.2). While holding mounting block in place, nail the J-channel foam mounting block to the outside of the house using hot-dipped galvanized 3-inch roofing nails or hot-dipped galvanized 16-penny spikes (Fig 2.3). The nails should be placed no more than 16-24 inches apart and must penetrate a minimum of 3/4 inch into solid wood or 1/2 inch into plywood or OSB.

Fig. 2.0

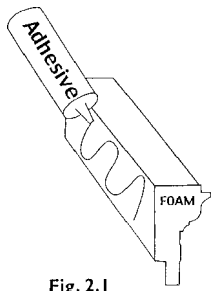

Fig. 2.1

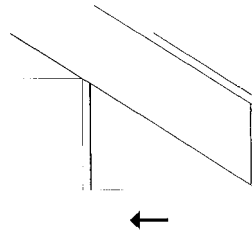

Fig. 2.2

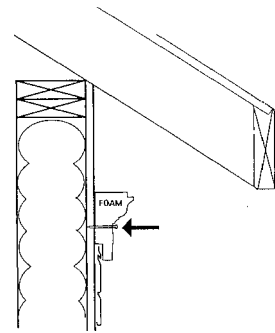

Fig. 2.3

Attaching the Frieze Trim

After the foam mounting blocks are attached, hook the bottom of the Frieze Trim to the foam mounting block (Fig 2.4) and rotate the Frieze Trim upwards, locking it in place. (Fig 2.5) Next, install soffit panels by inserting one end of the soffit panel all the way into the pre-formed J-channel on the top of the Frieze Trim (Fig 2.6) and nailing the other end of the soffit panel to the bottom of the fascia board using aluminum nails (Fig 2.7). Cover the fascia board with pre-formed fascia.

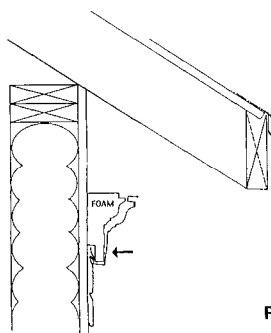

Fig. 2.4

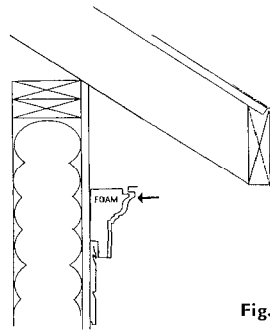

Fig. 2.5

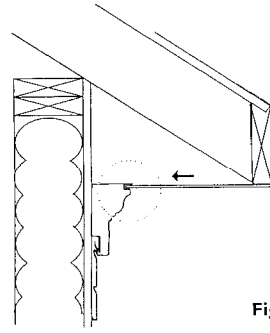

Fig. 2.6

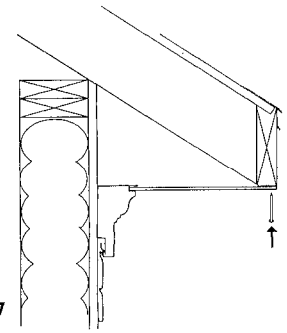

Fig. 2.7

INSTALLATION OF CCMi COPPER FRIEZE TRIM WITH BUILT IN BRICK POCKET

Frieze Trim with Built-in Brick Pocket has deeper foam mounting block than other Frieze Trims. Frieze with Built-in Brick Pocket fills in the area where the brick pocket normally would be framed with lumber, eliminating the need to frame a brick pocket.

Attaching the Foam Mounting Block

Apply 1/4 inch to 3/8 inch bead of adhesive to the foam mounting block as shown in Fig 3.1. After striking the chalk line (see Installation Order on page I), line up the top edge of the foam mounting block with the chalk line and press it firmly against the side of the house (Fig 3.2) . While holding mounting block in place, nail the J-channel foam mounting block to the outside of the house using 8-inch hot-dipped galvanized or aluminum gutter spikes (Fig 3.3). The spikes should be placed no more than 16-24 inches apart and must penetrate a minimum of 3/4 inch into solid wood studs. Generally, there should be no need for additional framing material as Frieze Trim with Built-in Brick Pocket covers the exposed brick pocket.

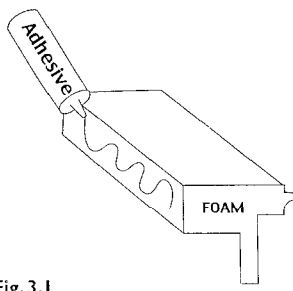

Fig. 3.1

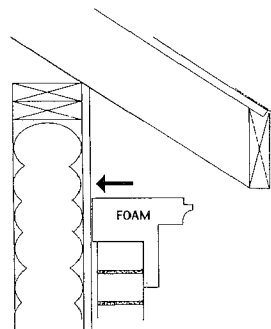

Fig. 3.2

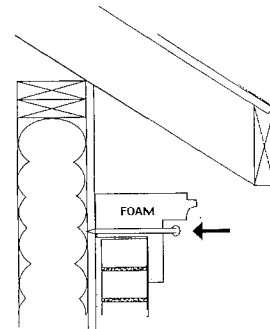

Fig. 3.3

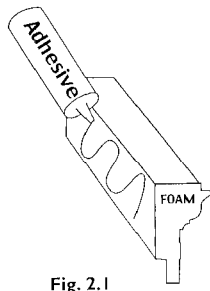

Fig. 2.1

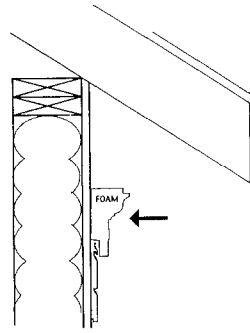

Fig. 2.2

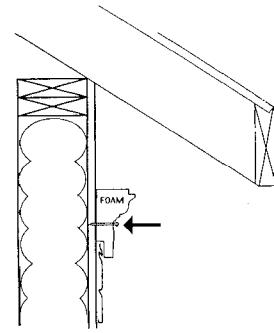

Fig. 2.3

Attaching the Frieze Trim

After the foam mounting blocks are attached, hook the bottom of the Frieze Trim to the foam mounting block (Fig 2.4) and rotate the Frieze Trim upwards, locking it in place. (Fig 2.5) Next, install soffit panels by inserting one end of the soffit panel all the way into the pre-formed J-channel on the top of the Frieze Trim (Fig 2.6) and nailing the other end of the soffit panel to the bottom of the fascia board using aluminum nails (Fig 2.7). Cover the fascia board with pre-formed fascia.

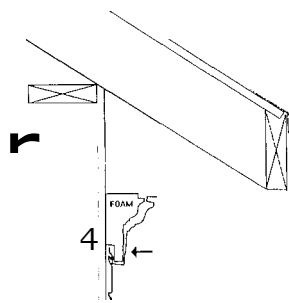

Fig.2.4

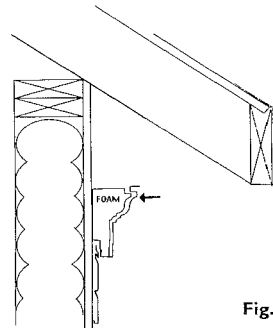

Fig.2.5

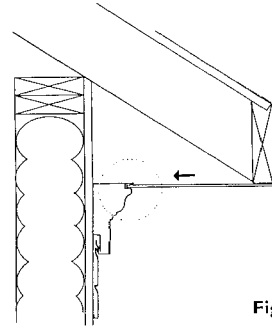

Fig. 2.6

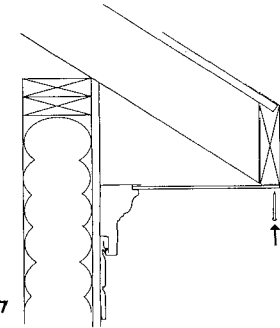

Fig. 2.7

INSTALLATION OF CCMi COPPER FRIEZE TRIM WITH BUILT IN BRICK POCKET

Frieze Trim with Built-in Brick Pocket has deeper foam mounting block than other Frieze Trims. Frieze with Built-in Brick Pocket fills in the area where the brick pocket normally would be framed with lumber, eliminating the need to frame a brick pocket.

Attaching the Foam Mounting Block

Apply 1/4 inch to 3/8 inch bead of adhesive to the foam mounting block as shown in Fig 3.1. After striking the chalk line (see Installation Order on page I), line up the top edge of the foam mounting block with the chalk line and press it firmly against the side of the house (Fig 3.2) . While holding mounting block in place, nail the J-channel foam mounting block to the outside of the house using 8-inch hot-dipped galvanized or aluminum gutter spikes (Fig 3.3). The spikes should be placed no more than 16-24 inches apart and must penetrate a minimum of 3/4 inch into solid wood studs. Generally, there should be no need for additional framing material as Frieze Trim with Built-in Brick Pocket covers the exposed brick pocket.

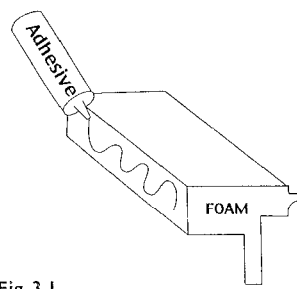

Fig. 3.1

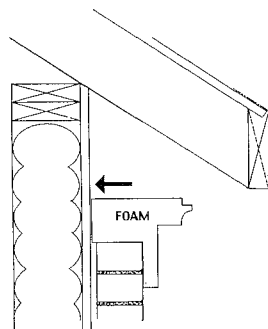

Fig. 3.2

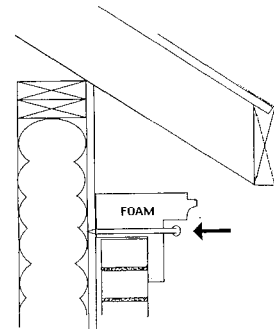
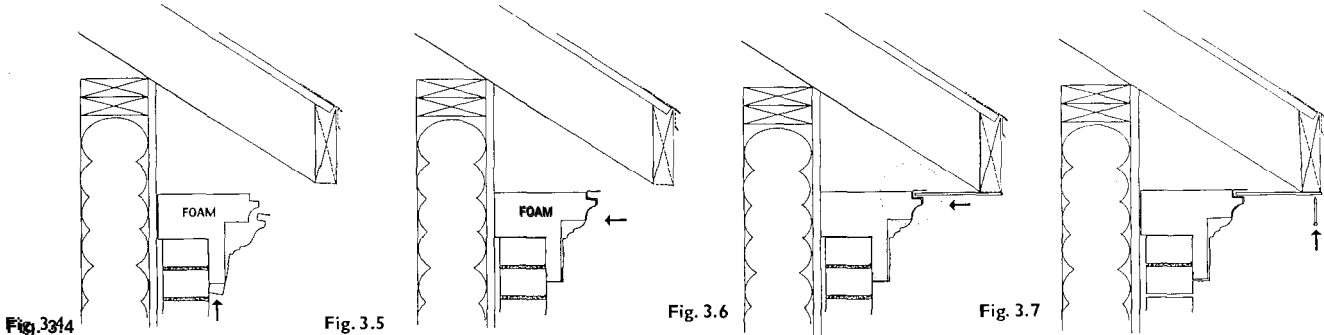

Fig. 3.3

Attaching the Frieze Trim

After the foam mounting blocks are attached, hook the bottom of the Frieze Trim to the foam mounting block (Fig 3.4) and rotate the Frieze Trim upwards and lock it in place (Fig 3.5). Next, install soffit panels by inserting one end of the soffit panel all the way into the pre-formed J-channel on the top of the Frieze Trim (Fig 3.6) and nailing the other end of the soffit panel to the bottom of the fascia board using aluminum nails (Fig 3.7). Cover the fascia board with pre-formed fascia.



The same procedures as above should be used to install Frieze Trim with Built-in Brick Pocket over stone.

SPECIAL INSTRUCTION FOR FRIEZE TRIM

Mitering and overlapping Frieze Trim can be accomplished with a little practice and by using the correct tools and following these instructions. A 12-inch slide compound miter saw with outrigger supports is necessary to produce quality miters. **IMPORTANT: ALWAYS CUT FRIEZE TRIM WITH THE FOAM BACKER IN PLACE.** A piece of flush-mount foam is supplied as a cutting aid with the brick pocket configuration. After cutting to length, install Frieze Trim as directed for each type: Flush, J-channel or Brick Pocket.

OVERLAPPING CONTOURS FRIEZE TRIM

Overlap the pieces of Frieze Trim by cutting 1 inch off both the top and bottom channels of the piece that is to be overlapped. If necessary, a small sliver of foam may be inserted behind the overlapped panel between the foam and trim to create a better overlap joint. **NOTE: Always lap away from the "line of sight".** To allow for expansion and contraction do not caulk lapped joints.

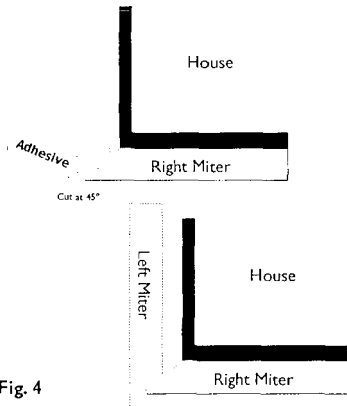

OUTSIDE CORNER MITER

To make a 90° outside miter, set the 12-inch slide compound miter saw to 45°. Place Frieze Trim on bed of saw, straight, level, and supported on both ends. Make one cut for each half of outside corner miter. Apply adhesive to the foam mounting block inside the miter. Install the mitered foam on both the front and side of the desired location using the proper installation procedures, as appropriate, as shown earlier for Flush, J-channel or Brick pocket.

After the foam mounting block is attached, hook the bottom of the Frieze Trim facing the front of the house to the foam mounting block, allowing this trim to extend 1/16 inch beyond end of foam at the miter, and then rotate the Frieze Trim upward and lock it in place (Fig 4). Now install the side trim by sliding the Frieze Trim over the foam until it touches the inside of the front trim. Finally apply a fine bead of sealant to the 1/16" extension to conceal the mitered joint. **NOTE: Making the front trim slightly longer will allow for a caulking bead and produce a more "finished look".**

INSIDE CORNER MITER

To make an inside miter, it is necessary to miter cut only one piece of Frieze Trim. On one side of the inside corner, install straight cut foam and trim, butting it fully into the corner. Set the 12-inch compound miter saw to 45°. Place Frieze Trim on bed of saw, straight, level, and supported on both ends. Cut the inside corner at a 45° miter. Using snips, remove the point of the J-channel from the mitered piece to allow it to butt fully into the corner.

Attach the mitered foam mounting block to the adjacent wall. The foam will only butt at the top of the frieze on the other wall, leaving a gap. This is acceptable...it is not necessary to cope the foam to fit into the corner. Next, slide the mitered Frieze Trim over the side foam until it touches the face of the adjacent trim. Caulk the inside corner as needed to finish (Fig 5).